

# THS/PL21 SERIES

## Quality Control at its finest



PIPELINE INTEGRATED SYSTEMS WITH METAL DETECTOR AND EJECTION VALVE

### FEATURES

- State-of-the Art Quality Control of liquid, viscous products and meat
- Detection and ejection of magnetic, non-magnetic and stainless steel metal contaminants
- Very high sensitivity. Multi spectrum technology available
- Fast detection and rejection speed
- Fail-Safe Operations
- Structure and components in AISI 316L stainless steel and food-compatible plastics [EU, FDA compliant]
- Rugged, IP65/66/69 construction
- Easy to disassemble and clean



### THS/PLVM21

Pass-through with ejection valve integrated system for applications on meat vacuum filler machines.



HEAT AND CONTROL

www.heatandcontrol.com



800 227 5980 • 510 259 0500 • info@heatandcontrol.com

Heat and Control reserves the right to make changes, at any moment and without notice, to the models, their accessories and options, to the prices and conditions of sale.



**CEIA is a manufacturing company specialized in the design, engineering and production of Metal Detectors.**

*The CEIA Integrated Systems are especially designed for the inspection of liquid, and viscous products and the elimination of any contaminating metals, whether magnetic, non-magnetic or stainless-steel.*

The CEIA integrated systems are especially designed for metal contaminant detection in products transported by pipeline especially meat, soup, preserves...

**The carefully selected materials used in construction do not interact with food products, and thus do not modify or alter their composition.** The design of these systems incorporates a fast reject valve drive response time to detect and reject the contaminant without slowing down the product flow.

**The construction guarantees quick, easy cleaning of the components that are in contact with the product.** The technological choices made by CEIA allow the parts in contact with the product to be disassembled and maintained in a short time.

**The systems operate in fail-safe mode,** thus avoiding the risk of contaminants passing through even when the system is deactivated or when the electrical power supply is interrupted.

**MULTI-SPECTRUM TECHNOLOGY**

Exclusively developed by CEIA, this is **a unique metal detection technology that both optimizes sensitivity to all metal contaminants and minimizes product effect in a very wide range of possible products.**

By recognizing the different frequency response of conductive products and metals, this innovative technology cancels product effect and maintains high performance levels for all types of metal contaminants, both magnetic and non-magnetic.

**The autolearn function used by CEIA Multi-Spectrum metal detectors** equates to the repetition of hundreds of conventional transits. It explores the whole spectrum of available frequencies in order to determine the best operating conditions resulting in unique detection performance.

**PIPELINE INTEGRATED SYSTEMS WITH METAL DETECTOR AND EJECTION VALVE**



**THS/PL 21** SERIES

**INTEGRATED SYSTEM WITH METAL DETECTOR FOR LIQUID AND VISCIOUS PRODUCTS**



**THS/PLV 21** SERIES

**INTEGRATED SYSTEM WITH METAL DETECTOR AND EJECTION VALVE FOR LIQUID AND VISCIOUS PRODUCTS**



**THS/PLVM 21** SERIES

**INTEGRATED SYSTEM WITH METAL DETECTOR AND EJECTION VALVE FOR MEAT**

# THS/PL21 SERIES

## PASS-THROUGH INTEGRATED SYSTEM FOR LIQUID AND VISCOUS PRODUCTS



### FEATURES

- Detection of magnetic, non-magnetic and stainless steel metal contaminants
- Very high sensitivity. Multi spectrum technology available
- Standard pipe sizes available to suit all applications
- AISI 316L stainless steel construction to IP66 and IP69K protection levels
- High immunity to environmental interference
- Control Panels are listed according to UL 508A and CSA-C22.2 No. 14-05
- Easy to clean and inspect
- Minimum installation space required
- Wide range of flanges available for connection to bagging and clipping machines



THS/PL21E, THS/PLMS21, THS/PLH21E and THS/PLHMS21 models

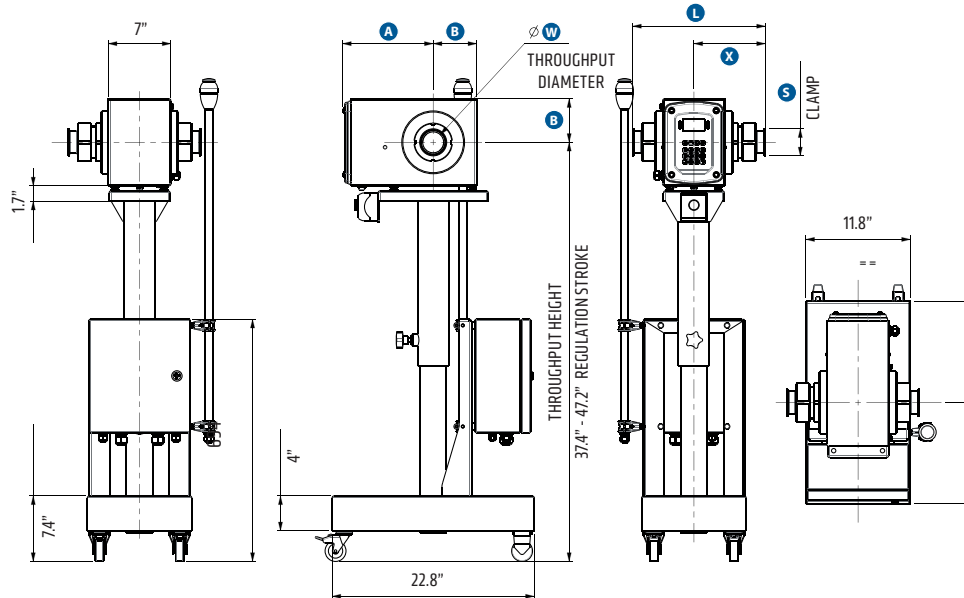

**THS/PLMS21** designed for metal contaminant detection in products transported by pipeline.

**THS/PLH21** [above] with integrated twisting extension kit.

MODEL	A	B	L	X	S	W
THS/PL-38	10"	5"	15"	8.2"	1.5"	Ø 1.2"
THS/PL-50				2"	Ø 1.9"	
THS/PL-63				2.5"	Ø 2.4"	
THS/PL-75				3"	Ø 2.9"	
THS/PL-100	11"	5.9"	18"	10.3"	4"	Ø 3.8"
THS/PLH-63	10"	5"	15"	8"	2.5"	Ø 2.4"

# THS/PLV21 SERIES

## PASS-THROUGH WITH EJECTION VALVE INTEGRATED SYSTEM FOR LIQUID AND VISCOUS PRODUCTS

### FEATURES

- Detection and ejection of magnetic, non-magnetic and stainless steel metal contaminants
- Very high sensitivity. Multi spectrum technology available
- Standard pipe sizes available to suit all applications
- Fast acting reject device for a limited quantity of rejected product
- Control Panels are listed according to UL 508A and CSA-C22.2 No. 14-05
- Wide range of flanges available for connection to bagging and clipping machines
- Easy to clean and inspect
- Minimum installation space required
- Very High Reliability
- Maximum Operator Safety



THS/PLV21E and THS/PLV21 models

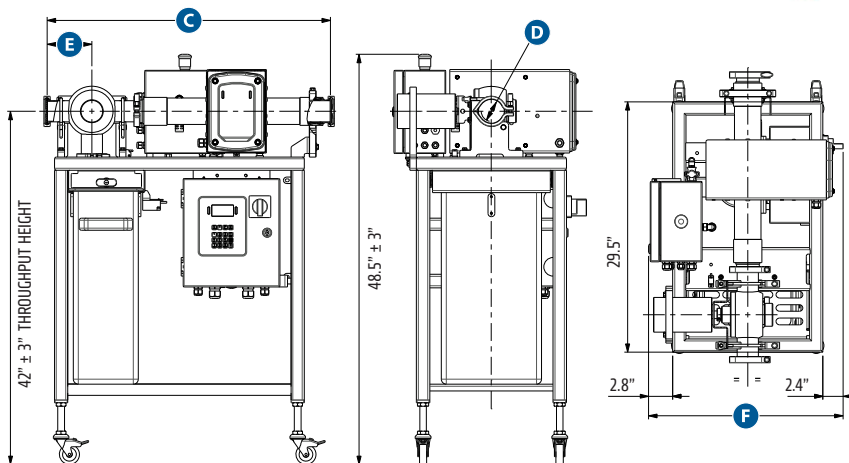

MODEL	C	D Internal Diameter	E	F
THS/PLV21-38	33.2"	1.5"	6.6"	23"
THS/PLV21E-38				
THS/PLV21-50	33.3"	2"	6.6"	23"
THS/PLV21E-50				
THS/PLV21-63	33.5"	2.5"	5.3"	23"
THS/PLV21E-63				
THS/PLV21-75	32.6"	3"	4.9"	24.8"
THS/PLV21E-75				
THS/PLV21-100	43"	4"	7"	25.7"
THS/PLV21E-100				



PRODUCT TRANSIT PIPE FEATURES

- FDA and EC 1935/2004 compliant
- High resistance to food industry C.I.P.
- Flanges integrated with pipe for best cleanability

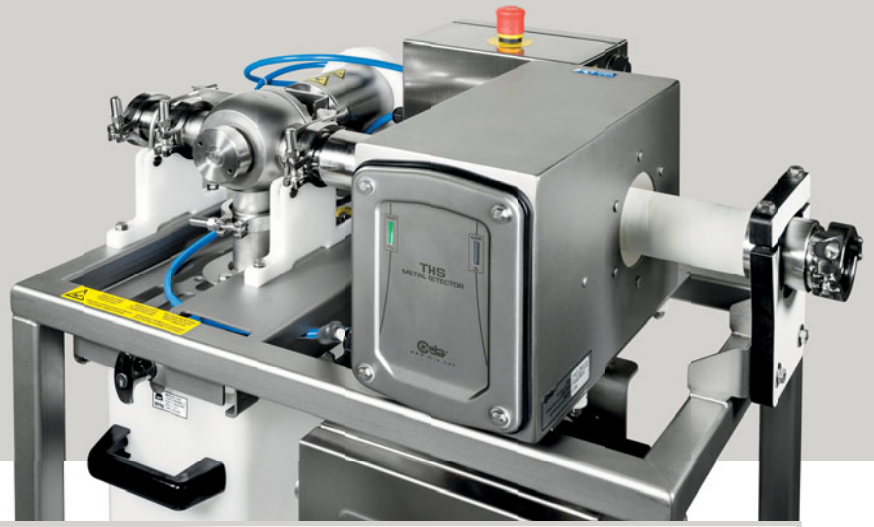

THS/PLV21E-C and THS/PLV21-C models

The system has been specially designed to be mounted on custom structures, without the rejected material bin.

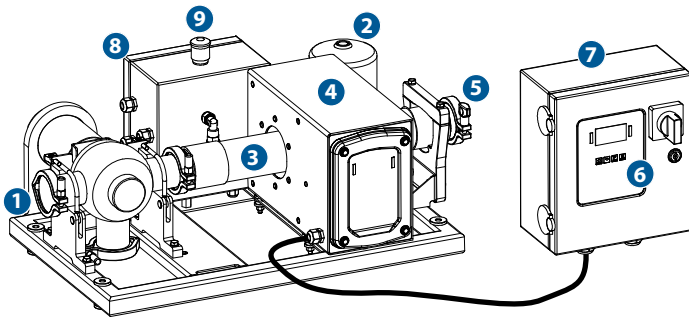

1	Inspected product exit
2	Pneumatic valve ejector
3	Product conveyor tube
4	Metal Detector probe
5	Product entrance
6	Control panel
7	Power-supply and control unit, for connecting the device to mains power and to the external supports
8	Pneumatic box
9	Emergency stop

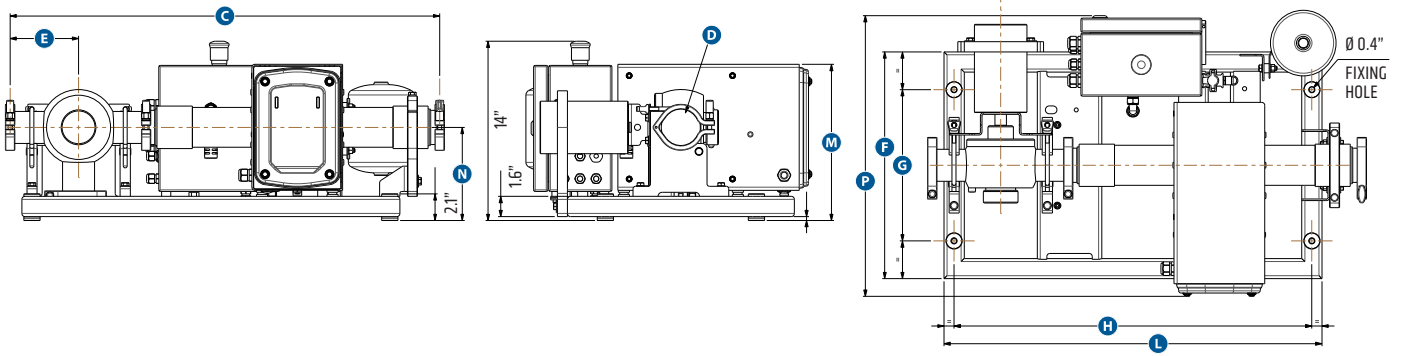

MODEL	C	D Internal Diameter	E	F	G	H	L	M	N	P
THS/PLV21-38C	33.2"	1.5"	6.6"	18"	11.8"	28"	29.5"	12.2"	7.3"	22"
THS/PLV21E-38C										
THS/PLV21-50C	33.3"	1.9"	6.6"	18"	11.8"	28"	29.5"	12.2"	7.3"	22"
THS/PLV21E-50C										
THS/PLV21-63C	33.6"	2.5"	5.3"	18"	11.8"	28"	29.5"	12.2"	7.3"	22"
THS/PLV21E-63C										
THS/PLV21-75C	33.2"	3"	4.9"	18"	11.8"	28"	29.5"	12.2"	7.3"	23.7"
THS/PLV21E-75C										
THS/PLV21-100C	43"	4"	7"	20"	11.8"	36"	37.5"	14.2"	8.3"	25.7"
THS/PLV21E-100C										

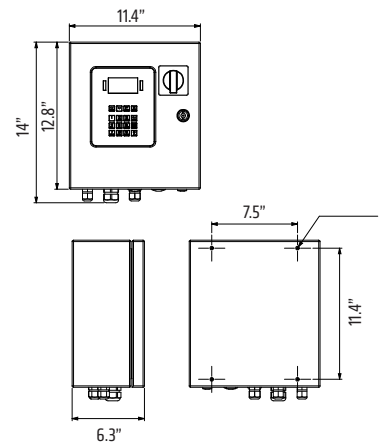

# THS/PLVM21 SERIES

## PASS-THROUGH WITH EJECTION VALVE INTEGRATED SYSTEM FOR APPLICATIONS ON MEAT VACUUM FILLER MACHINES

### FEATURES

- Detection and ejection of magnetic, non-magnetic and stainless steel metal contaminants
- Very high sensitivity. Multi spectrum technology available
- Standard pipe sizes available to suit all applications
- AISI 316L stainless steel construction to IP69K protection level
- High immunity to environmental interference
- Fast acting reject device for a limited quantity of rejected product
- Easy to clean and inspect
- Minimum installation space required
- Very High Reliability

### The THS/PLVM21 series is design to operate in Harsh conditions

- Use of high pressure levels
- High risk of impact during movement and handling operations.
- Strong vibration working conditions due to the filler and clipper machines
- Hard wash down conditions



#### Alarm signalling

High-visibility LED with IP69K water protection. The cap is completely filled with resin, which ensures mechanical resistance and water tightness.

#### Reset and emergency button

Integrated in a Stainless Steel waterproof box in order to reduce possible effects of dirt and to protect electrical cables which could be damaged during cleaning.



The THS/PLVM21 series is designed for metal contaminant detection in products transported by pipeline especially meat.

The technological choices made by CEIA allow the parts in contact with the product to be disassembled and maintained in a short time.

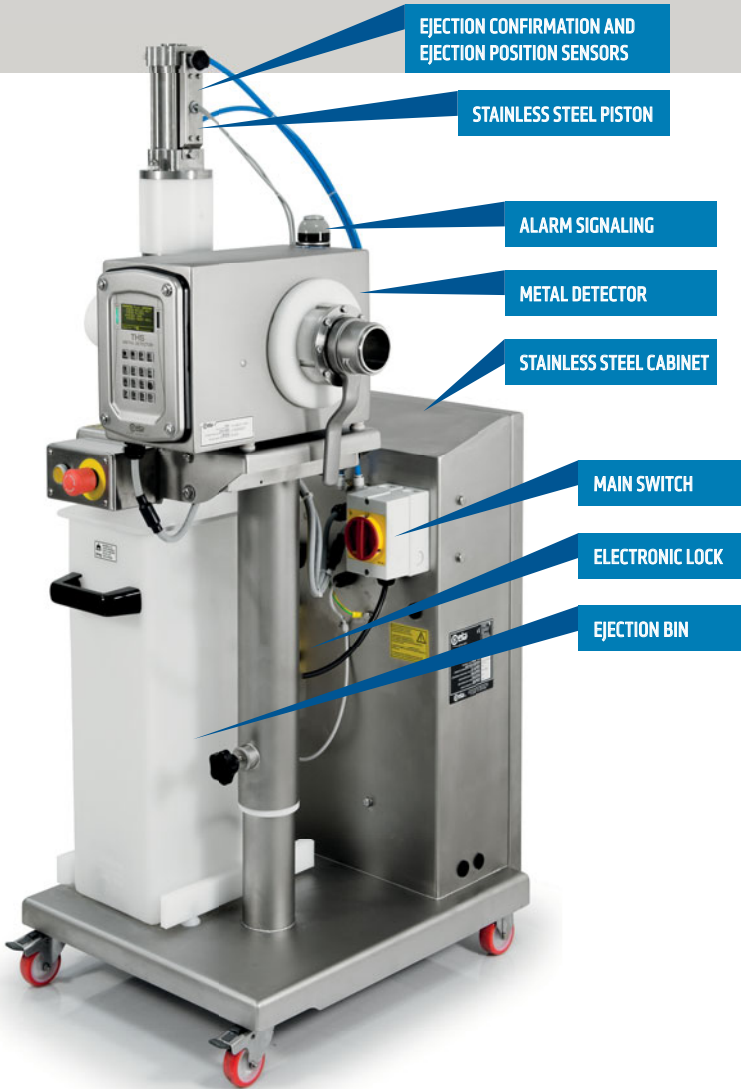

THS/PLVM21E and THS/PLVM21 models

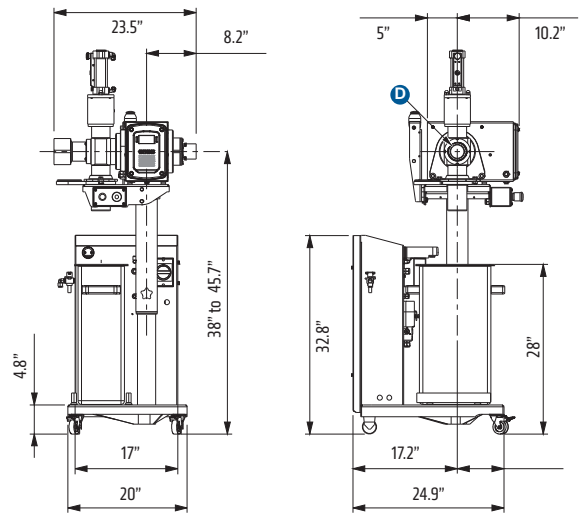

MODEL	D (Internal Diameter)
THS/PLVM21-63	2.5"
THS/PLVM21E-63	

LOCAL AND ADVANCED CONNECTIVITY [optional]



Stainless steel cabinet

Completely watertight, the cabinet protects both pneumatic and electronic components. The smooth surface facilitates cleaning procedure.



Stainless steel piston

## PIPELINE INTEGRATED SYSTEMS SPECIFICATIONS



## SPECIAL FEATURES

	THS/XX21E	THS/XX21
Detection sensitivity	High	Ultra High
Immunity to environmental interference	High	High
Data display type	Alphanumeric OLED - 4x20 characters	High-contrast graphical OLED 128x64 pixels
Local programming	4 keys, 3 with double function	16 keys, 3 with double function
Control Power Box or Conveyor Control System according to Standards UL 508A and CSA-C22.2 No. 14-05	on request	on request
Construction compliant with 21 CFR Parts 210 and 211		
All parts in contact with the product are in FDA approved materials for food contact		
Audio and visual detection indicators		
Display of the signal level by means of bar graph		
Inspected/contaminated product counter		
Autolearn and automatic tracking of the product effect		
ISO 9001 certified manufacturer		

## DATA MANAGEMENT

Management of electronic production data and electronic signatures as per CFR 21, Part 11

Data security / Data integrity / Data traceability

## EVENTS STORAGE

Complete monitoring of occurred events

Ejections / Test results / Programming accesses / Programming operations / Faults

## I/O INTERFACES

RS232, Auxiliary RS232, Bluetooth, Ethernet interface (on request), WI-FI and USB (on request)

## SIGNALLING

Acoustic

Via internal buzzer

Optical

Graphic display with bar-graph indication

Light indicators on control unit: RED: Alarm or Fault / GREEN: Power on

## PROGRAMMING

Local: built-in keyboard and high-contrast display

Remote: through computer connected via Bluetooth, RS232, Ethernet or WiFi and managed with CEIA MD Scope software, THS Production Plus software or any other terminal emulation program or through Web Server (with optional IXC card)

## SAFETY AND SECURITY

Protection degree

THS/XX21E IP65

THS/PLV21X and THS/PLVM21X IP66 – IP69K

On UL versions, the Control Power Box and Conveyor Control System have a 4X-12 certified degree of protection

Electrical insulation

Galvanic isolation of the mains voltage

Compliant with international standards for safety and radio interference

Acoustic emission

Acoustic pressure according to Directive 2006/42/EC: <70 dB(A); <130 dB(C)

Pollution degree (IEC61010-1)

Class 2

Installation category (IEC61010-1)

Category II

## SUPPLY

Control Power Box

Main voltage 100-240 VAC

Frequency and phase 50/60 Hz - single phase

Full load current (FLA) 2.2 A

Pneumatic system

Stainless steel waterproof container (protection degree: IP66 – IP69K)

Pressure 0.6 ÷ 1 MPa

Flow 100 l/min

## ENVIRONMENTAL CONDITIONS

Temperature

Operating 14°F to 131°F (-10 to +55 °C)

Storage THS/PLV 21x - THS/PLVM 21x: -13°F to 131°F (-25 to +55°C)

158°F (70°C) for short periods, 24h max

THS/PL 21x: -40°F to 158°F (-40 to +70°C)

Relative humidity

Operating / Storage 5 – 90 %, non-condensing

## PRODUCT CONDITIONS

Maximum temperature (for higher temperatures, contact CEIA)

Product in transit

THS/PLV 21x: 158°F (70°C)

THS/PLVM 21x: 140°F (60°C)

Inside the rejected material bin 158°F (70°C)

Maximum allowed pressure (for higher pressures, contact CEIA)

Transit pipe

1 MPa (THS/PLV 21x - THS/PLVM 21x)

1 MPa with product up to 60°C (THS/PL 21x)

0.6 MPa with product up to 90°C (THS/PL 21x)

21121 Cabot Blvd. Hayward, CA 94545 USA

Phone 1 800 227 5980 / 1 510 259 0500 • Fax 1 510 259 0600 • info@heatandcontrol.com

[www.heatandcontrol.com](http://www.heatandcontrol.com)

Heat and Control reserves the right to make changes, at any moment and without notice, to the models, their accessories and options, to the prices and conditions of sale.